

AREA DI MARCATURA

POSIZIONE DI "0"

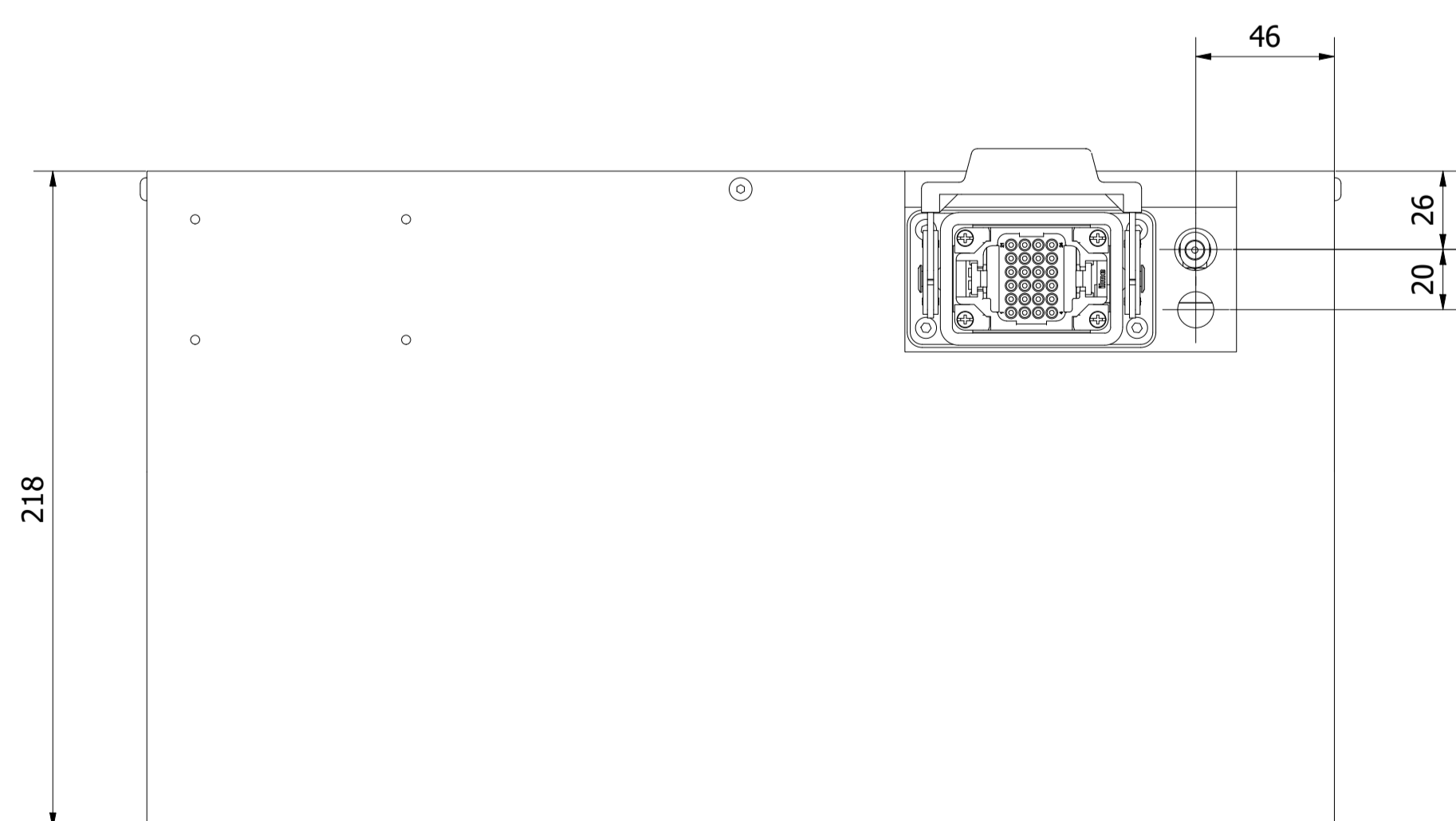
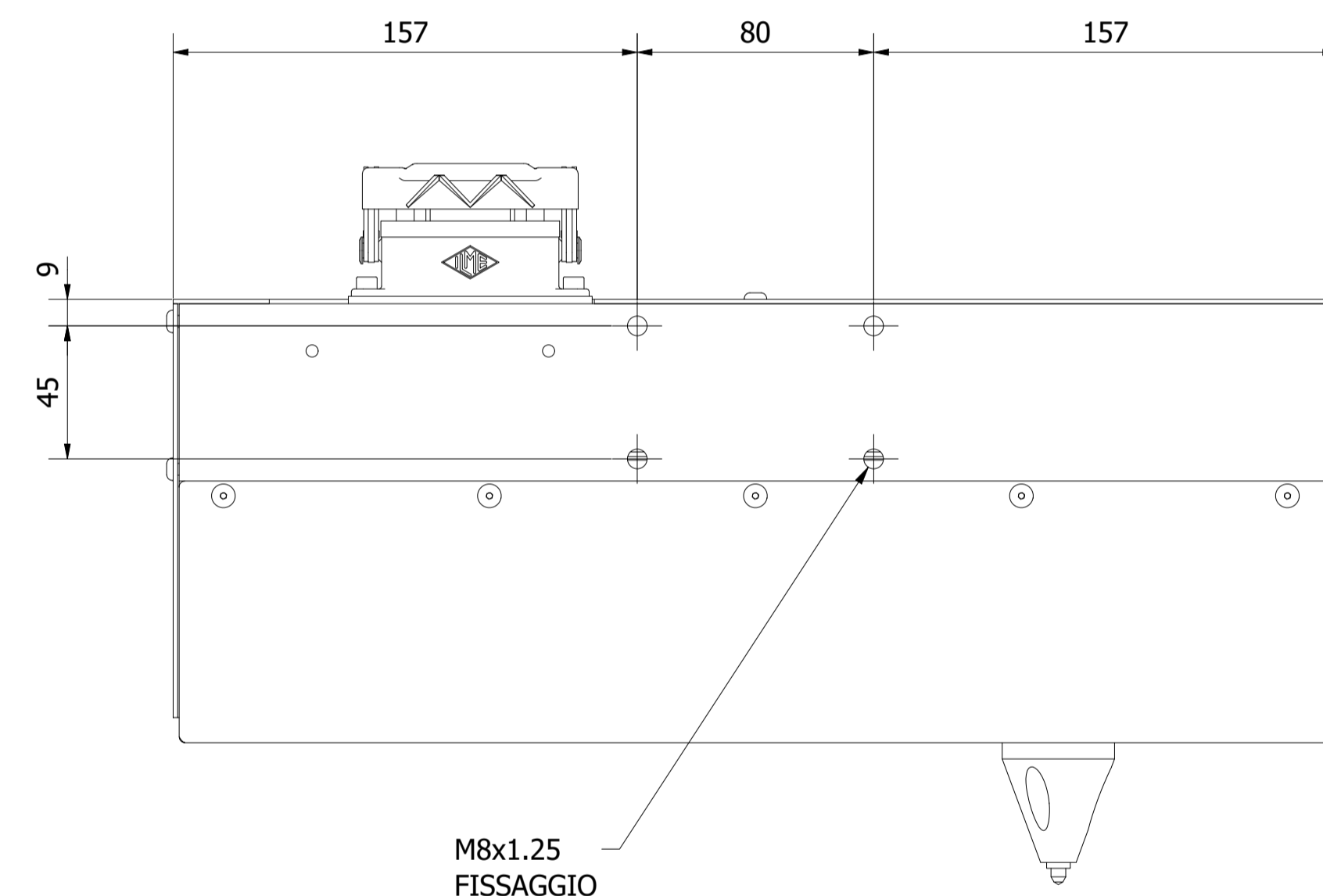
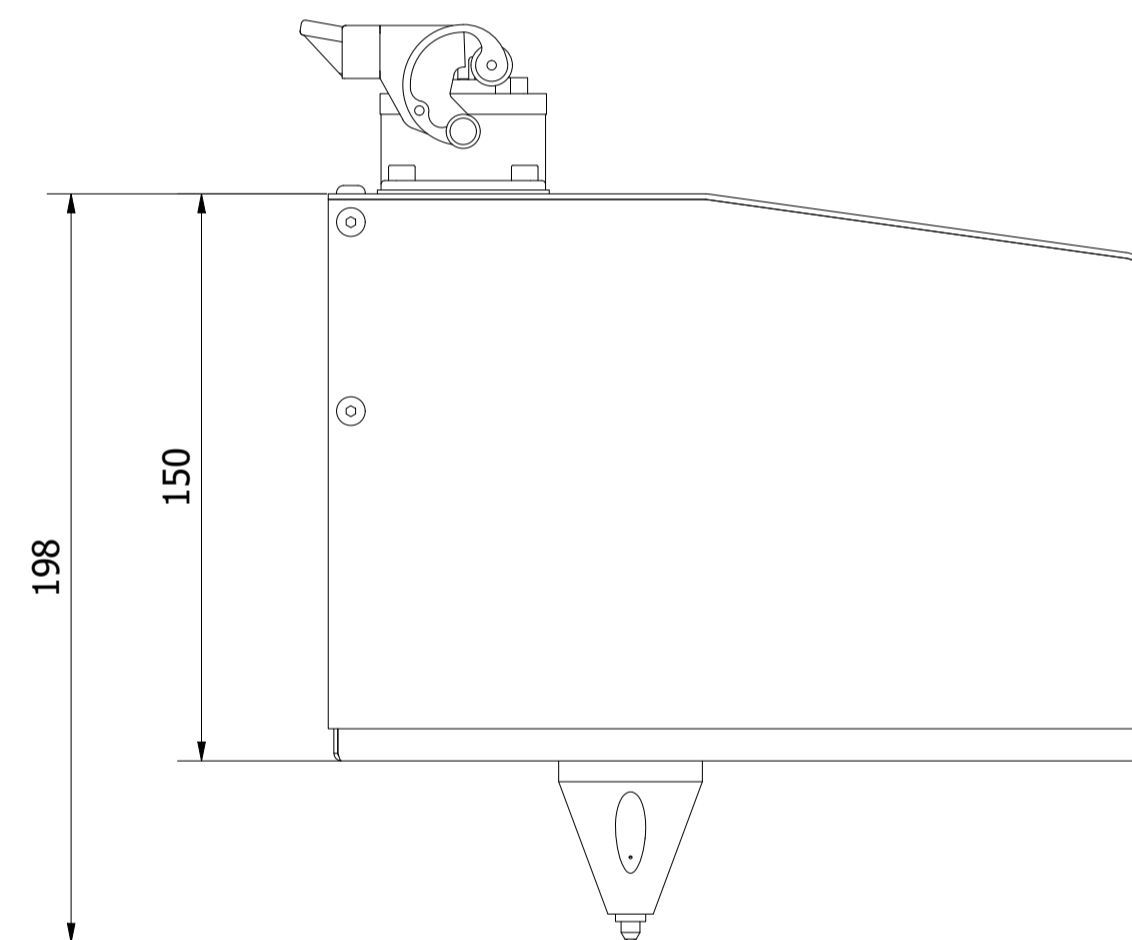
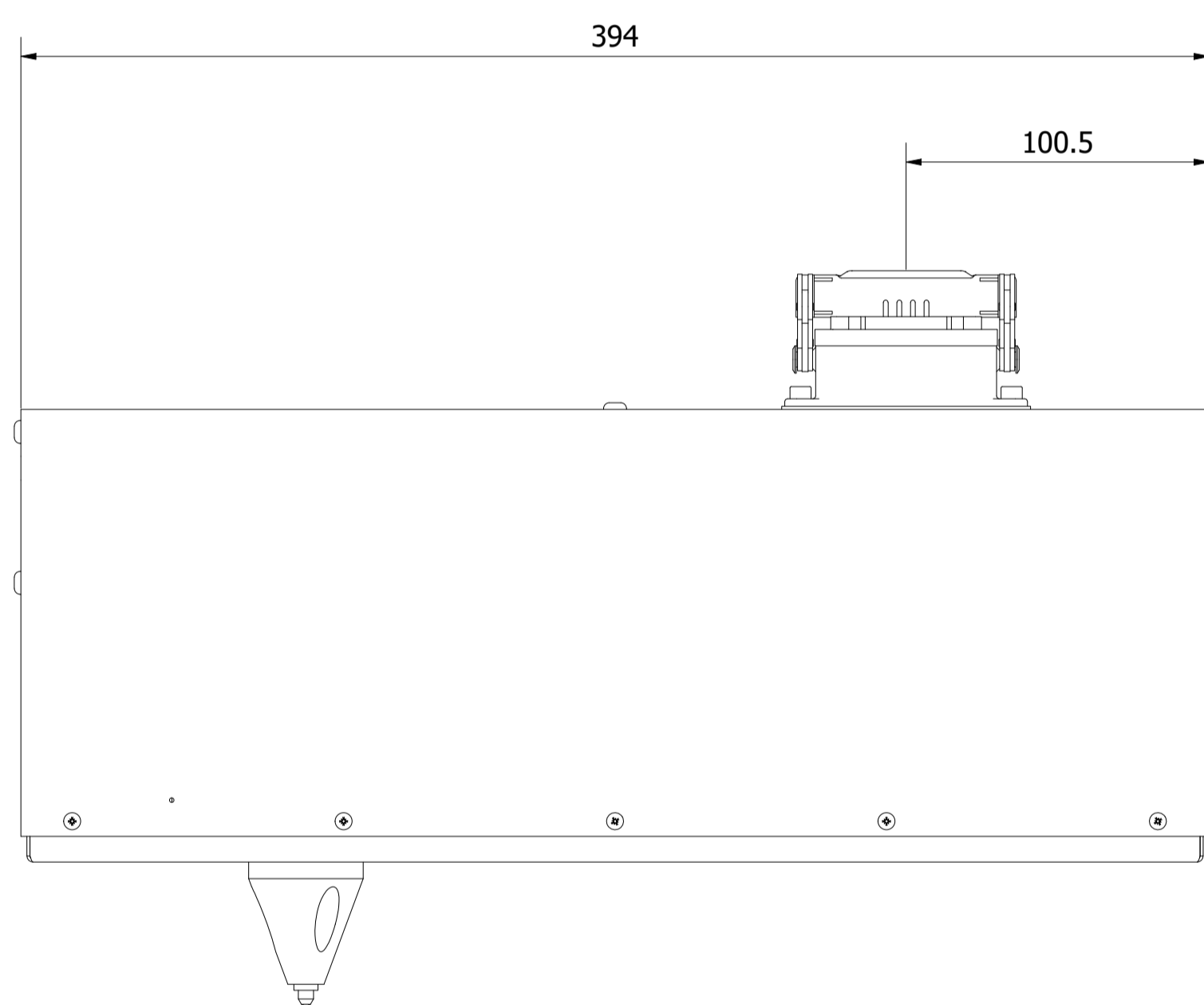
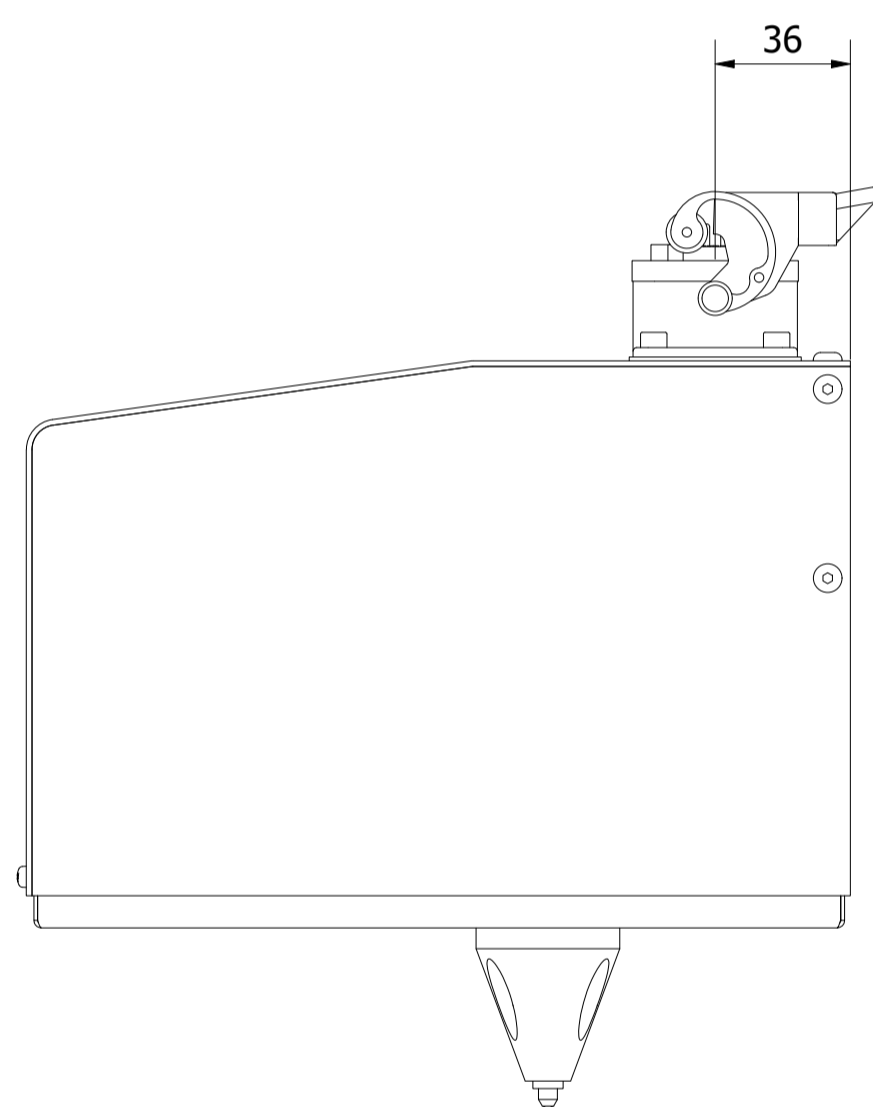
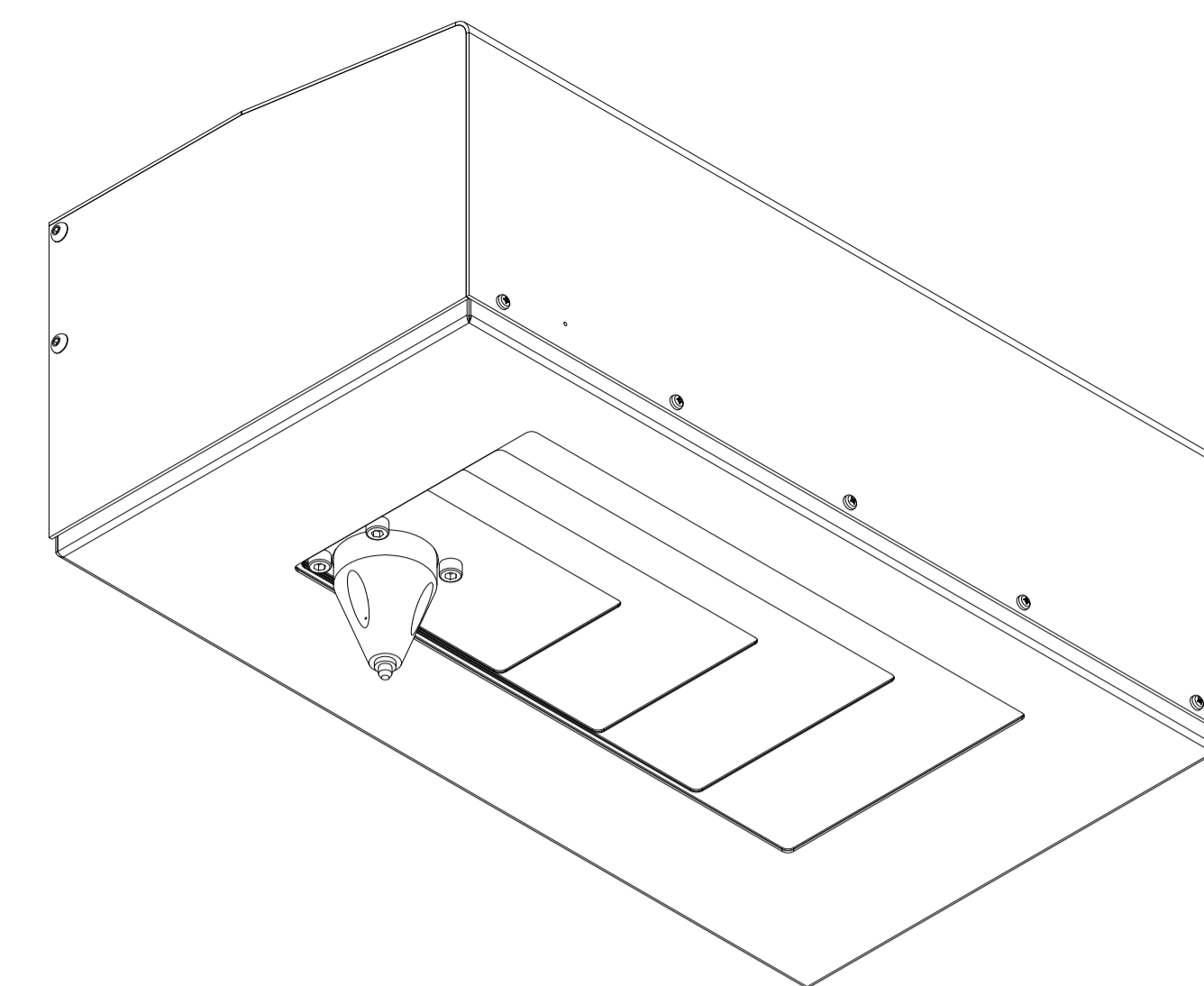
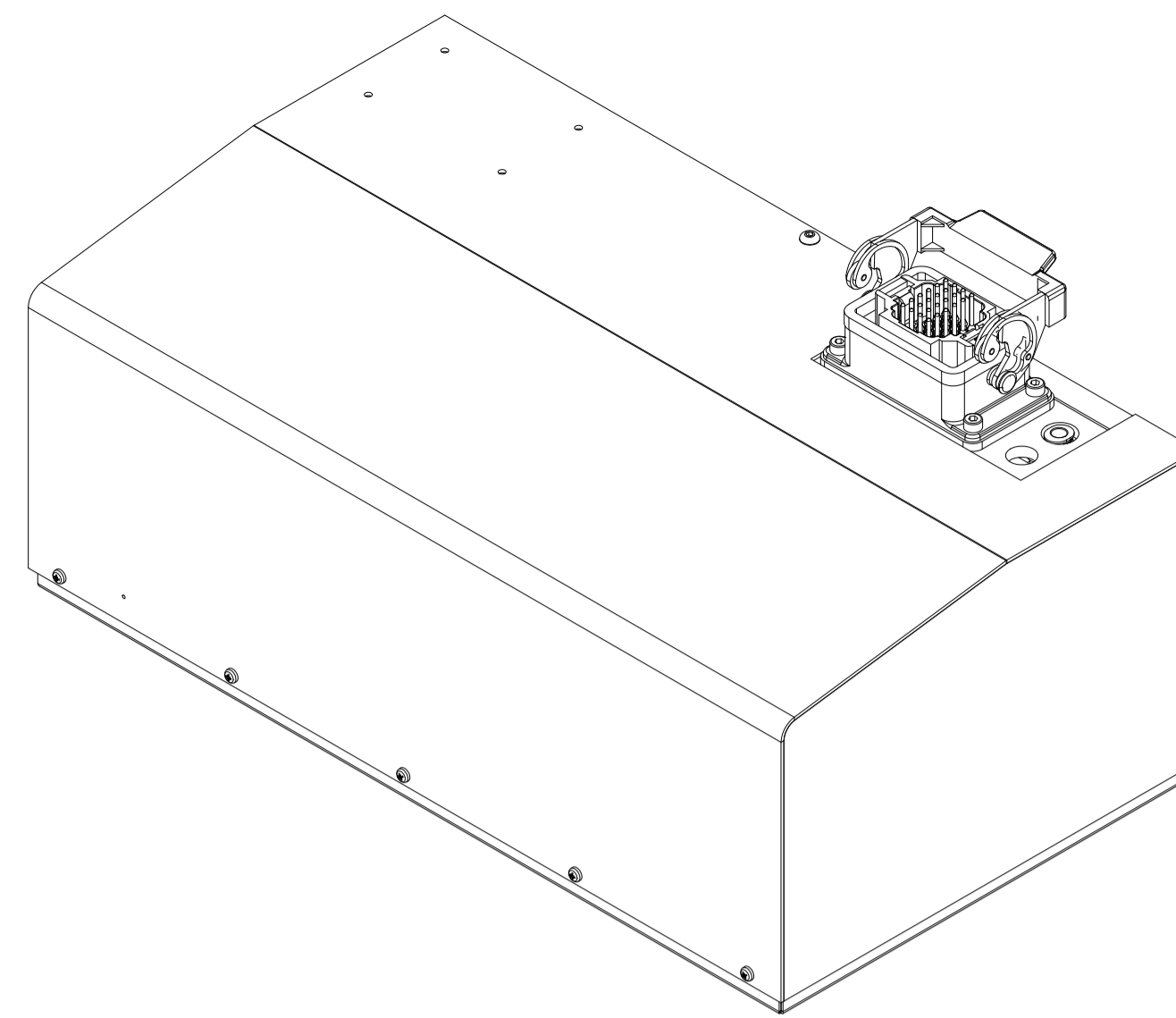
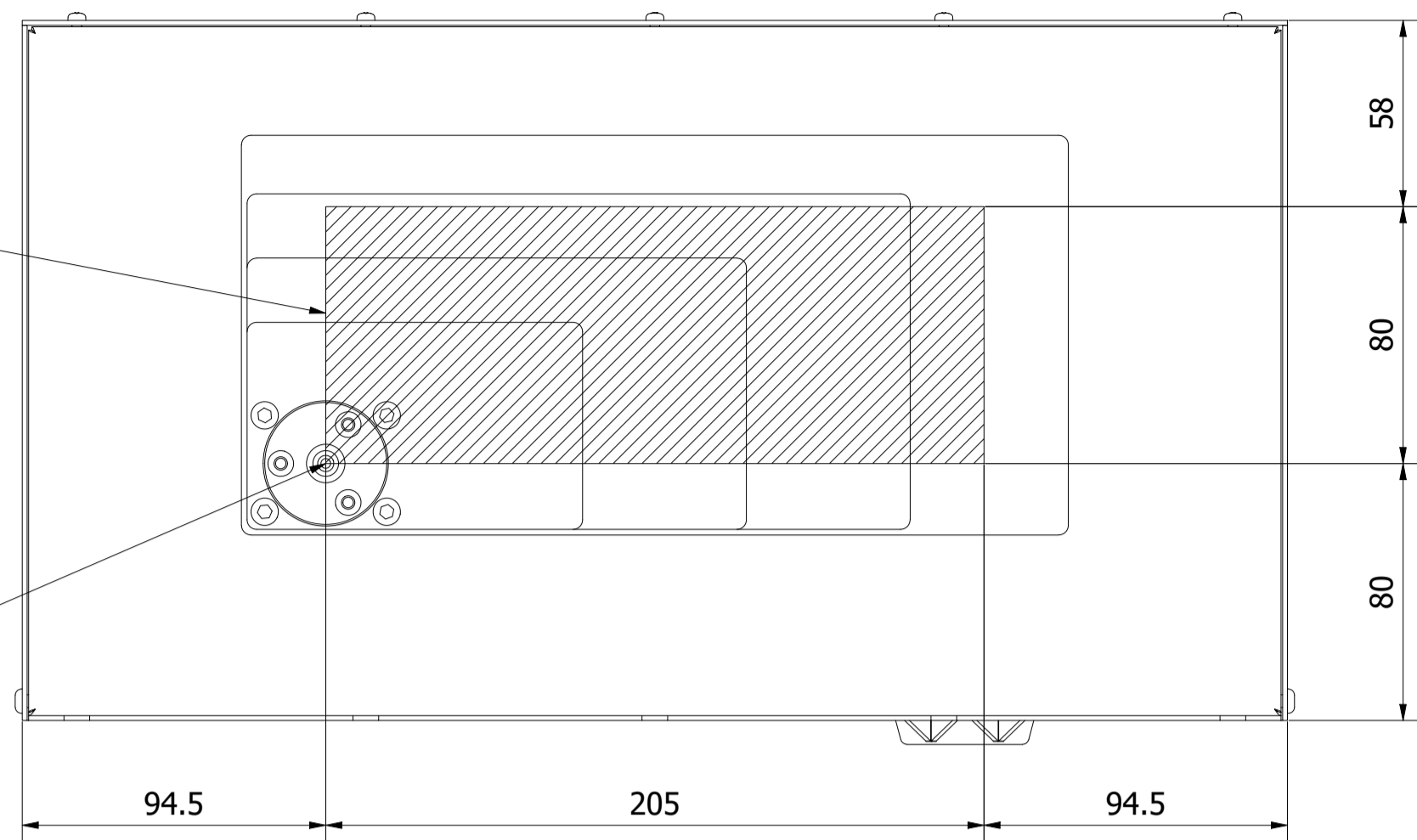

Nota/Note: soggetto a cambiamenti senza preavviso / subject to change without notice

Progettato da F. Bruno	Controllato da Deltavisione	Data 04/10/2018	Commessa	Scala 1 : 2
Materiale	Trattamento Finitura	Trattamento Termico	Durezza	Quantità 1



Proprietà di Delta Visione srl - Senza autorizzazione scritta il presente disegno non può venire utilizzato né comunicato a terzi e/o riprodotto. All property rights reserved to Delta Visione srl - This drawing shall not be reproduced or in any way utilized without written permission.

Descrizione
Marcatore a incisione

Nr. disegno
DEV7-2081-(R-X)

<p>Dove non specificato: Tol. generale ±0.1 mm Foro H13 Albero h13 Filettature GH/6g Sm. 0.5x45°</p>	<p>Revisione 00</p>	<p>Foglio 1 / 1</p>
--	-------------------------	-------------------------